



FMP100

Plug and Play tracker

Quick Manual
V1.4

Table of Contents

Table of Contents	2
Know your device	3
Know your device	4
Set up your device	5
How to insert Nano-SIM card	5
PC Connection (Windows)	6
Configuration (Windows)	6
Quick SMS configuration	8
User Interface	9
Keyboard	9
Basic characteristics	9
Safety information	12
Certification and Approvals	13
Warranty	14
Warranty Disclaimer	14

Know your device

Side view

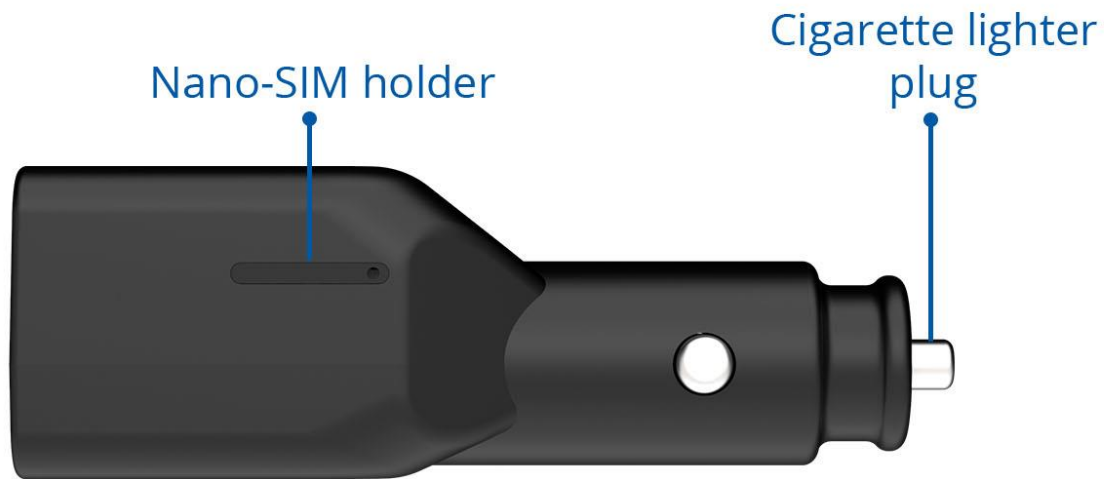

Front view (with cover)

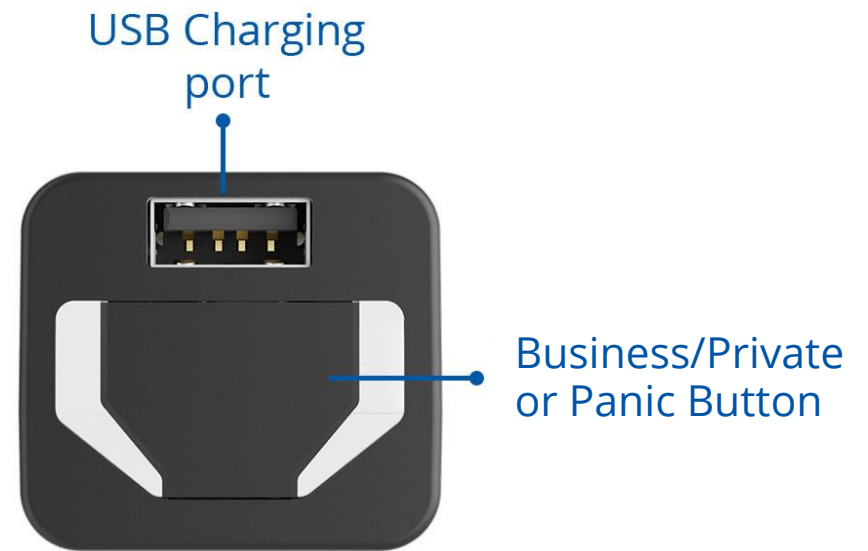
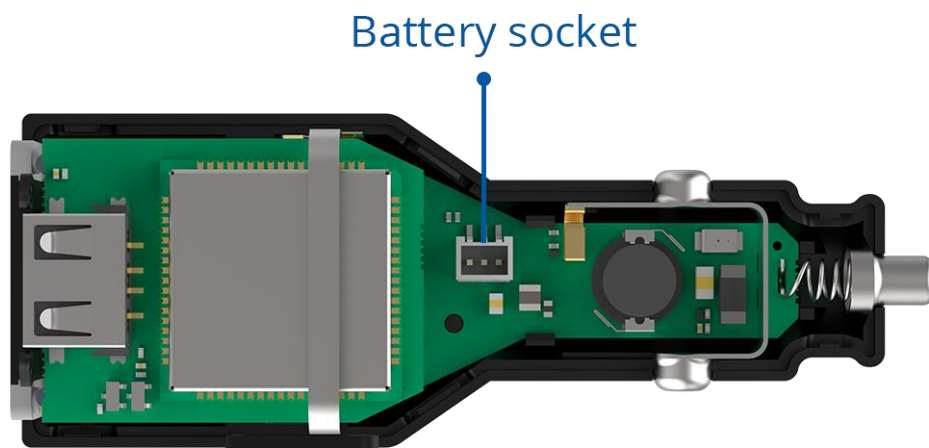

Figure 1 FMP100 device view (With covers)

Know your device

Top view (without cover)



Front view (without cover)

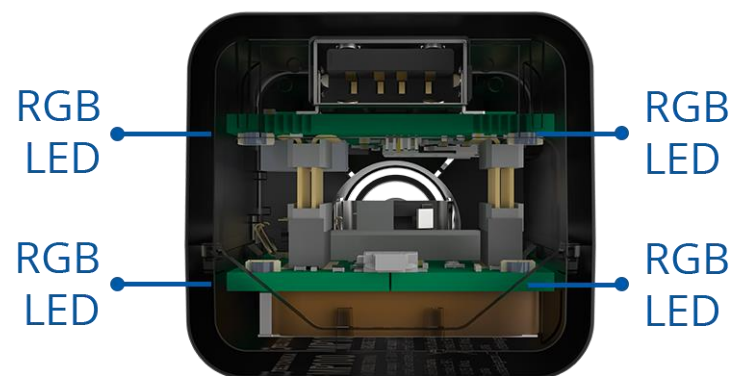

Set up your device

How to insert Nano-SIM card

1. Insert the SIM tray removal tool into the hole on the SIM card tray and then push until the tray pops out.
2. Insert **Nano-SIM** card as shown with **PIN request disabled** or read our [Wiki](#) how to enter it later in [Teltonika Configurator](#). Make sure that Nano-SIM card is fitted properly into the tray.
3. Insert the SIM card tray back.
4. After **configuration**, see "[PC Connection \(Windows\)](#)".

Device is ready to be mounted.

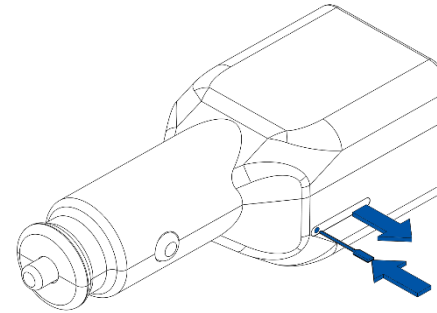

1

Figure 3 SIM tray removal

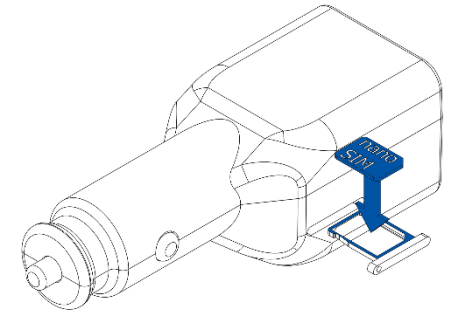

2

Figure 3 Nano-SIM card insert

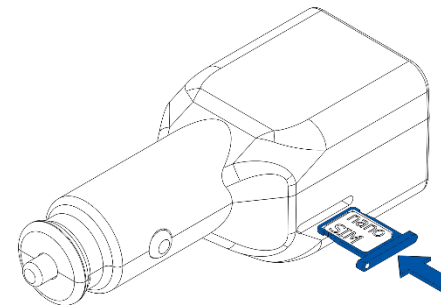

3

Figure 4 SIM tray insert

PC Connection (Windows)

- Connection by using **Bluetooth**:
 - 1) Power-up FMP100 with **DC voltage (12 – 30 V)** power supply. LED's should start blinking, see "[Error! Reference source not found.](#)".
 - 2) FMP100 Bluetooth is enabled by default. Turn on **Bluetooth** on your PC, then select **Add Bluetooth or other device > Bluetooth**. Choose your device named – "**FMBxxx_last_7_imei_digits**", without **LE** in the end. Enter default password **5555**, press **Connect** and then select **Done**.
- If Bluetooth connection is not possible, please refer to the [FMP100 Wiki page](#) on how to open the device casing and connect it via **Micro-USB**.

Configuration (Windows)

At first FMP100 device will have default factory settings set. These settings should be changed according to the user's needs. Main configuration can be performed via [Teltonika Configurator](#) software. Get the latest **Configurator** version from [here](#). Configurator operates on **Microsoft Windows OS** and uses prerequisite **MS .NET Framework**. Make sure you have the correct version installed.

Table 1 MS .NET requirements

MS.NET REQUIREMENTS			
Operating system	MS .NET Framework version	Version	Links
Windows Vista Windows 7 Windows 8.1 Windows 10	MS .NET Framework 4.6.2	32 and 64 bit	<u>www.microsoft.com</u>

Downloaded **Configurator** will be in compressed archive. Extract it and launch **Configurator.exe**. After launch software language can be changed by clicking  in the right bottom corner ([Figure 5 Language selection](#)).

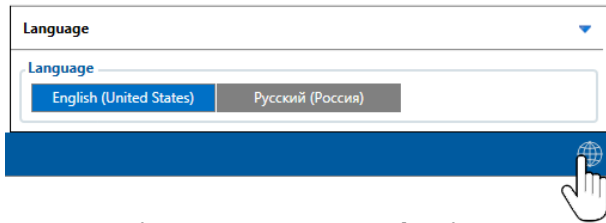

Figure 5 Language selection

Configuration process begins by pressing on connected device (Figure 6 Device connected via Bluetooth).



Figure 6 Device connected via Bluetooth

After connection to Configurator **Status window** will be displayed (Figure 7 Configurator Status window).

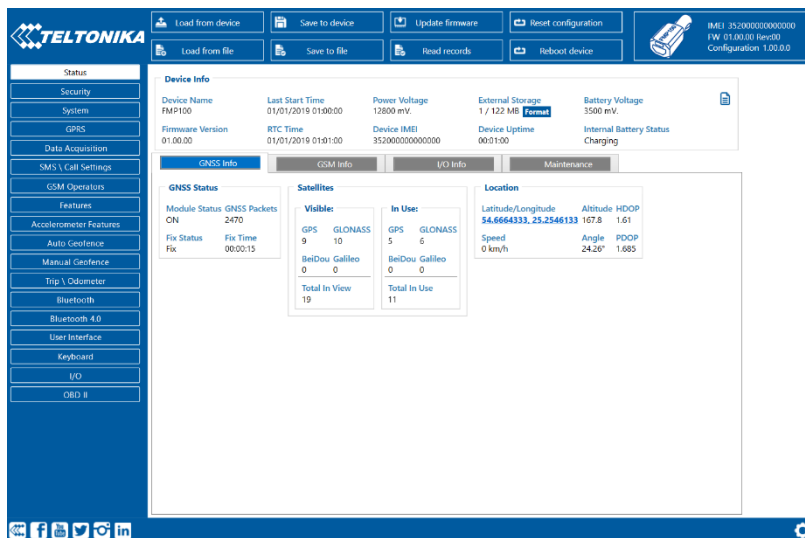

Figure 7 Configurator Status window

Various [Status window](#) tabs display information about [GNSS](#), [GSM, I/O](#), [Maintenance](#) and etc. FMP100 has one user editable modification of configuration the changes need to be saved to device using **Save to device** button. Main buttons offer following functionality:

1. **Load from device** – loads configuration from device.
2. **Save to device** – saves configuration to device.
3. **Load from file** – loads configuration from file.
4. **Save to file** – saves configuration to file.
5. **Update firmware** – updates firmware on device.
6. **Read records** – reads records from the device.
7. **Reboot device** – restarts device.
8. **Reset configuration** – sets device configuration to default.

Most important configurator section is **GPRS** – where all your server and [GPRS settings](#) can be configured and [Data Acquisition](#) – where data acquiring parameters can be configured.

More details about FMP100 configuration using Configurator can be found in our [Wiki](#).

Quick SMS configuration

Default configuration has optimal parameters present to ensure best performance of track quality and data usage.

Quickly set up your device by sending this SMS command to it:

```
" setparam 2001:APN;2002:APN_username;2003:APN_password;2004:Domain;2005:Port;2006:0"
```

Note: Before SMS text, two space symbols should be inserted.

GPRS settings:

- 2001 – APN
- 2002 – APN username (if there are no APN username, empty field should be left)
- 2003 – APN password (if there are no APN password, empty field should be left)

Server settings:

- 2004 – Domain
- 2005 – Port
- 2006 – Data sending protocol (0 – TCP, 1 – UDP)



Default configuration settings

Movement and ignition detection:



Vehicle movement will be detected by accelerometer



Ignition will be detected by vehicle power voltage between 13,2 – 30 V

Device makes a record **On Moving** if one of these events happen:



300 seconds passes



Vehicle turns 10 degrees



Vehicle drives 100 meters



Speed difference between last coordinate and current position is greater than 10 km/h

Device makes a record **On Stop** if:



1 hour passes while vehicle is stationary and ignition is off

Records sending to server:



If device has made a record it is sent to the server every 120 seconds

After successful SMS configuration, FMP100 device will **synchronize time** and **update records** to **configured server**. Time intervals and default I/O elements can be changed by using [Teltonika Configurator](#) or [SMS parameters](#).

User Interface

Table 3 User interface LED indication scenarios

SCENARIO	INDICATION	MEANING
GSM error	Red LED 500 ms blink 3 times + Buzzer	SIM is not inserted, device can't connect to the operator or GSM signal is being jammed
No GNSS fix	Red LED 1000 ms blink 1 time	Device doesn't have valid GNSS fix and is searching for coordinates
GNSS fix	Green LED 1000 ms blink 1 time	Device has valid GNSS fix
Key pressed	1000 ms interval Buzzer while active	Key is pressed and held
Private Trip	Green LED 500 ms blink 3 times + Buzzer	Battery is almost fully discharged
Business Trip	Blue LED 500 ms blink 3 times + Buzzer	Indication used to remind the user that device is still operational

Note! This table contains only the default scenarios. Additional scenarios/default ones can be modified using [Teltonika Configurator](#). User is able to select different indication color (Red, Green or Blue), frequency of LED blinking and buzzer status.

Keyboard

Table 4 Keyboard default actions

ACTION	FUNCTION
1 Click	Check Trip Mode
2 Clicks	Change Trip Mode
Long Click	Alarm

Basic characteristics

Table 5 Basic characteristics

MODULE	
Name	Teltonika TM2500
Technology	GSM/GPRS/GNSS/BLUETOOTH
GNSS	
GNSS	GPS, GLONASS, GALILEO, BEIDOU, SBAS, QZSS, DGPS, AGPS
Receiver	33 channel
Tracking sensitivity	-165 dBm
Position accuracy	< 2.5 CEP
Velocity accuracy	< 0,1 m/s (within +/- 15% error)
Hot start	< 1 s
Warm start	< 25 s
Cold start	< 35 s

CELLULAR

Technology	GSM
2G bands	Quad-band 850 / 900 / 1800 / 1900 MHz
Data transfer	GPRS Multi-Slot Class 12 (up to 240 kbps)
Data support	SMS (text/data)

POWER

Input voltage range	10 - 30 V DC with overvoltage protection
Back-up battery	3.7 V 170 mAh (0.63 Wh)
Power consumption	At 12V < 5 mA (<u>Ultra Deep Sleep</u>) At 12V < 7 mA (<u>Deep Sleep</u>) At 12V < 7 mA (<u>Online Deep Sleep</u>) At 12V < 8 mA (<u>GPS Sleep</u>) At 12V < 28 mA (nominal)

BLUETOOTH

Specification	4.0 + LE
Supported peripherals	Temperature and Humidity sensor , Hands-free headset , Inateck Barcode Scanner, Universal BLE sensor support

INTERFACE

Connection	Cigarette lighter socket
Configurable buttons	1
GNSS antenna	Internal High Gain
GSM antenna	Internal GSM High Gain

USB	1 x USB 2.0 Micro-USB for configuration 1 x USB type A for external device charging (5V 1A)
LED indication	RGB LED
SIM	Nano-SIM
Memory	128MB internal flash memory

PHYSICAL SPECIFICATION

Dimensions	96,7 x 33,4 x 27,5 mm (L x W x H)
------------	-----------------------------------

OPERATING ENVIRONMENT

Operating temperature (without battery)	-40 °C to +85 °C
Storage temperature (without battery)	-40 °C to +85 °C
Operating humidity	5% to 95% non-condensing
Ingress Protection Rating	IP41
Battery charge temperature	0 °C to +45 °C
Battery discharge temperature	-20 °C to +60 °C
Battery storage temperature	-20 °C to +45 °C for 1 month -20 °C to +35 °C for 6 months

FEATURES

Sensors	Accelerometer
Scenarios	Green Driving , Over Speeding detection , Jamming detection , GNSS Fuel Counter , Excessive Idling detection , Unplug detection , Towing detection , Crash detection , Auto Geofence , Manual Geofence , Trip
Sleep modes	GPS Sleep , Online Deep Sleep , Deep Sleep , Ultra Deep Sleep

Configuration and firmware update	FOTA Web , FOTA , Teltonika Configurator (USB, Bluetooth), FMBT mobile application (Configuration)
SMS	Configuration, Events, Debug
GPRS commands	Configuration, Debug
Time Synchronization	GPS, NITZ, NTP
Fuel monitoring	OBDII
Ignition detection	Accelerometer, External Power Voltage

Safety information

This message contains information on how to operate FMP100 safely. By following these requirements and recommendations, you will avoid dangerous situations. You must read these instructions carefully and follow them strictly before operating the device!

- The device uses SELV limited power source. The nominal voltage is +12 V DC. The allowed voltage range is +10...+30 V DC.
- To avoid mechanical damage, it is advised to transport the device in an impact-proof package. Before usage, the device should be placed so that its LED indicators are visible. They show the status of device operation.
- Before unmounting the device from vehicle, ignition **MUST** be **OFF**.



Do not disassemble the device. If the device is damaged, the power supply cables are not *isolated* or the isolation is damaged, DO NOT touch the device before unplugging the power supply.



All wireless data transferring devices produce interference that may affect other devices which are placed nearby.



The programming must be performed using a PC with autonomic power supply.



Installation and/or handling during a lightning storm is prohibited.



The device is susceptible to water and humidity.



Teltonika is not responsible for any harm caused by wrong cables used for connection between PC and FMP100



WARNING! Do not use FMP100 device if it distracts driver or causes inconvenience due to cigarette lighter socket placement. Device must not interfere with driver.



Battery should not be disposed of with general household waste. Bring damaged or worn-out batteries to your local recycling center or dispose them to battery recycle bin found in stores.

Certification and Approvals

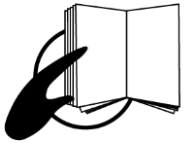

This sign on the package means that it is necessary to read the User's Manual before your start using the device. Full User's Manual version can be found in our [Wiki](#).



This sign on the package means that all used electronic and electric equipment should not be mixed with general household waste.



Hereby, Teltonika declare under our sole responsibility that the above described product is in conformity with the relevant Community harmonization: European Directive 2014/53/EU (RED).

Warranty

TELTONIKA guarantees its products to be free of any manufacturing defects for a period of **24 months**. With additional agreement we can agree on a different warranty period, for more detailed information please contact our sales manager.

Contact us teltonika.it/company/contacts

All batteries carry a reduced 6 month warranty period.

If a product should fail within this specific warranty time, the product can be:

- Repaired
- Replaced with a new product
- Replaced with an equivalent repaired product fulfilling the same functionality
- TELTONIKA can also repair products that are out of warranty at an agreed cost.

Warranty Disclaimer

TELTONIKA PRODUCTS ARE INTENDED TO BE USED BY PERSONS WITH TRAINING AND EXPERIENCE. ANY OTHER USE RENDERS THE LIMITED WARRANTIES EXPRESSED HEREIN AND ALL IMPLIED WARRANTIES NULL AND VOID AND SAME ARE HEREBY EXCLUDED. ALSO EXCLUDED FROM THIS LIMITED WARRANTY ARE ANY AND ALL INCIDENTAL OR CONSEQUENTIAL DAMAGES INCLUDING BUT NOT LIMITED TO, LOSS OF USE OR REVENUE, LOSS OF TIME, INCONVENIENCE OR ANY OTHER ECONOMIC LOSS.

More information can be found at teltonika.it/warranty-repair